

Chrysler presents the finest of the "4's"

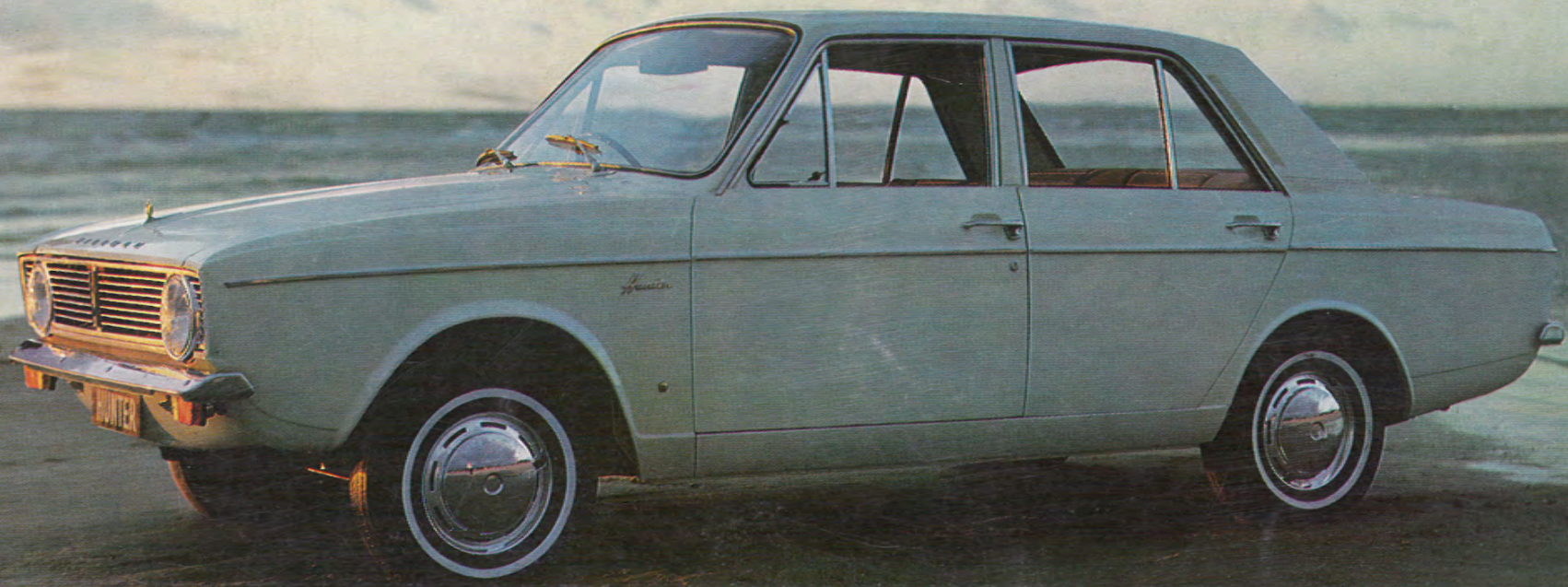

HILLMAN  
*Arrow &  
Hunter*

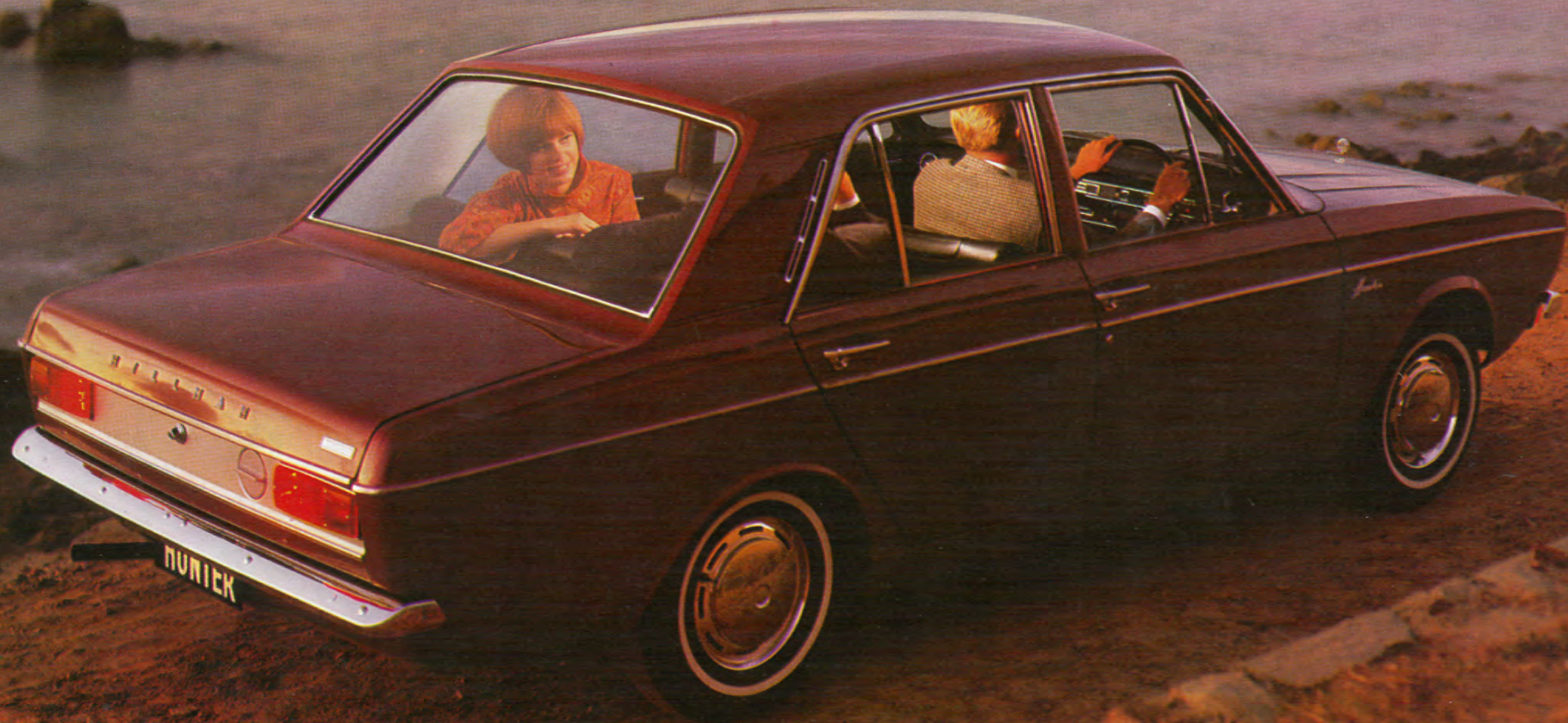

**Crisp, clean styling . . . long sleek lines**

The Hillman Arrow and Hunter represent a major break-through in economical family motoring. They combine a superb blend of practical modern design with top quality comfort and styling. Big inside, the Arrow and Hunter are still compact in overall size. Slant engine gives lower bonnet line, and curved side windows provide generous interior width. The lightweight, tough, all-steel body results in excellent power-to-weight ratio, and provides a real "zest" for performance with outstanding economy.

**HILLMAN**  
*Arrow &  
Hunter*

**From the same  
stable as the famous  
Chrysler Valiant**

Immediately Valiant was introduced, it was recognised and accepted as being the leader and prestige car of the popular "sixes". In presenting the new Hillman Arrow and Hunter, Chrysler, with the same top quality, sets the trend and establishes new leaders in the economical family motoring field. "The finest of the 4's."



**Spacious, luxuriously comfortable**

Both Arrow and Hunter offer full travel comfort for five adults. Individual front seats are form contoured for maximum comfort and support, and are independently adjustable. Rear seat is full-width and cradled well within the wheelbase, yet allows ample leg room. A wide parcel shelf is located behind the rear seat and also below the instrument panel. Ash trays are located in each of the four wide doors. Front doors operate courtesy light.

Further refinements exclusive to Hunter include lush interior trim, fully reclining front passenger seat, rich carpeting, cigarette lighter, armrests to all doors, trunk light, wheel trim rings and whitewall tyres. Arrow or Hunter, both are created for maximum comfort, both are finished to the highest standard of Chrysler quality.



**Clear View Instruments:** The spokeless top half of the steering wheel ensures a clear view of instruments. Screen reflections are eliminated by the moulded binnacle-type instrument panel.

**Dished Steering Wheel:** Designed for safety and light, precise control. A master stalk switch located on the steering column operates the turning indicators, headlamp dimmer and horn.

### Easier, safer driving

Driving comfort is really exceptional. Instruments and controls are designed for maximum ease, efficiency and safety. Turning circle is only 33.5 ft. All instruments and switches are recessed and grouped in front of the driver — easy to see and reach. The angled gear lever is mounted in the centre floor console, ready to hand. Handbrake is conveniently positioned to the right of the driver. Twin sun visors and instrument panel are padded for safety.

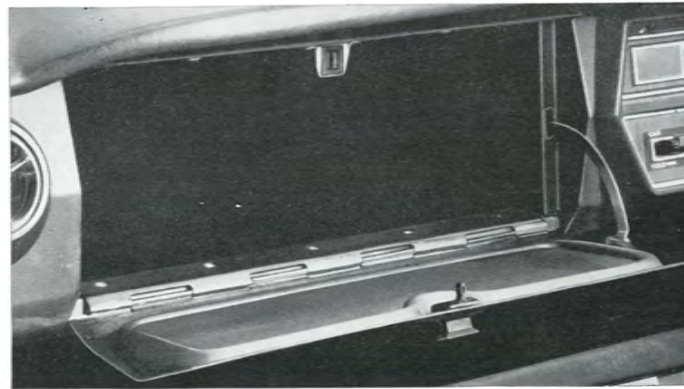

**Glove Box:** Styled into the instrument panel and located in front of the front passenger. Lid hinges down and is held in the horizontal open position.





**Smooth, effortless performance . . . to 'go places' with economy**

The sleek look and low bonnet line is not just styling with Arrow and Hunter. The "air-flow" design gives high performance travel. You get flexibility over the entire speed range with lively response from the "slant 4" 1725 c.c. engine. Acceleration through the gears is swift, with ample power for sustained cruising and hill climbing. You travel in comfort and safety too. The refined system of suspension ensures a smooth even ride—stability at all speeds, tenacious road grip and firm cornering. Safety features including disc brakes, and double-sided safety rim wheels ensure that the Arrow and Hunter are among the safest cars on the road today.



### All the family luggage

The Hillman Arrow and Hunter are family-size cars, with family-size baggage accommodation — 18 cubic feet of usable space in the luggage boot. The boot lid is spring assisted, opens easily and locks securely. (Hunter also incorporates a trunk light). The floor of the boot is covered with a protective mat and the spare wheel is easily accessible. There's room for everything the family needs — for daily travel or holiday tours.

### Five-seater space and comfort

Driver and front passenger travel in individual comfort. The curved side windows provide extra shoulder and hip room. There is generous leg room and all seating is contoured for maximum comfort. Full-width rear seat easily accommodates three adults. There is also plenty of room for travel requisites. A large parcel shelf under the instrument panel, another shelf behind the rear seat, and an enclosed glove box. All interior appointments of the Arrow and Hunter are of top-quality and fine finish.

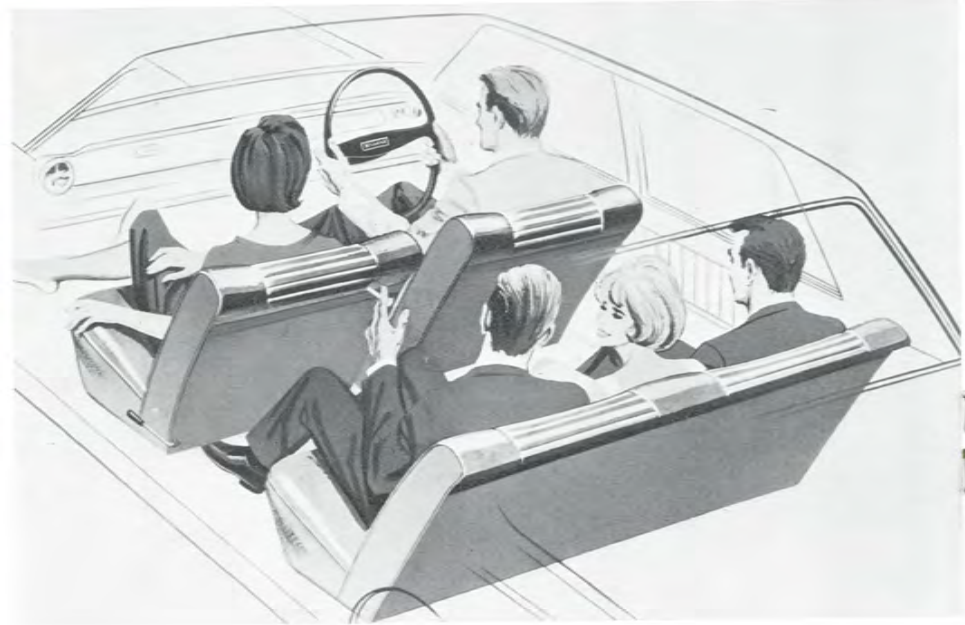

## Value-for-money features

With advanced technical features, refinements, comprehensive appointments, positive economy, and an in-built safety, the Hillman Arrow and Hunter offer the **greatest all-round value** within their price range. Your Chrysler Hillman Dealer will gladly introduce you to all the outstanding features of the Hillman Arrow and Hunter.



**Centre Console:** Neatly housing the gear lever in manual transmission models. All four forward gears are fully synchromesh.



**Fully Automatic Transmission:** Available on both Arrow and Hunter. Gear selector lever and selector panel are styled into the centre floor console.



**Seat Belt Anchor Points:** Seat belt anchorages are already installed for both front seats. These points are conveniently located for simple fixing.

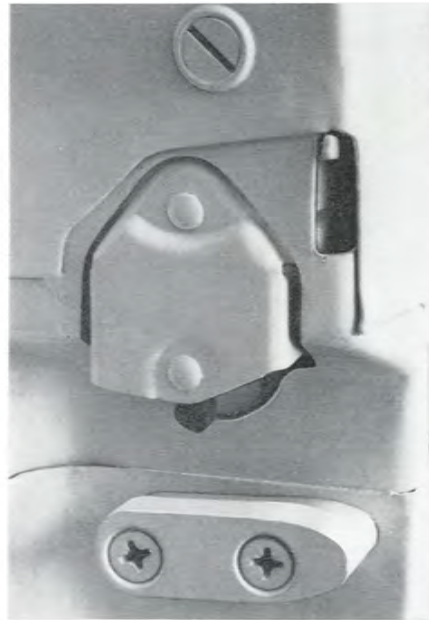

**Child-Proof Locks:** Fitted to both rear doors. Simply set the safety catch and doors cannot be opened from the inside. All doors have anti-burst locks.



**Safety Windscreen:** The wide-arc, dual windscreen wipers sweep a wide area for clear vision in inclement weather. The modified zone area of the windscreen, in front of the driver, provides driving vision in the event of screen being crazed or shattered by flying stones. Windscreen washers are standard equipment on both Arrow and Hunter.

## You travel relaxed with new controlled, fresh air ventilation

You can't be comfortable in a stuffy or draughty car, so an advanced ventilation system has been built into both the Arrow and Hunter. One that is **really** efficient. The air in the interior is always fresh, even with the windows closed. Air is circulated throughout the interior and automatically extracted. Heater and demisters are standard equipment on the Hunter. (Available as an optional extra, at time of order, on Arrow). Both Arrow and Hunter feature opening vent windows to the front doors.

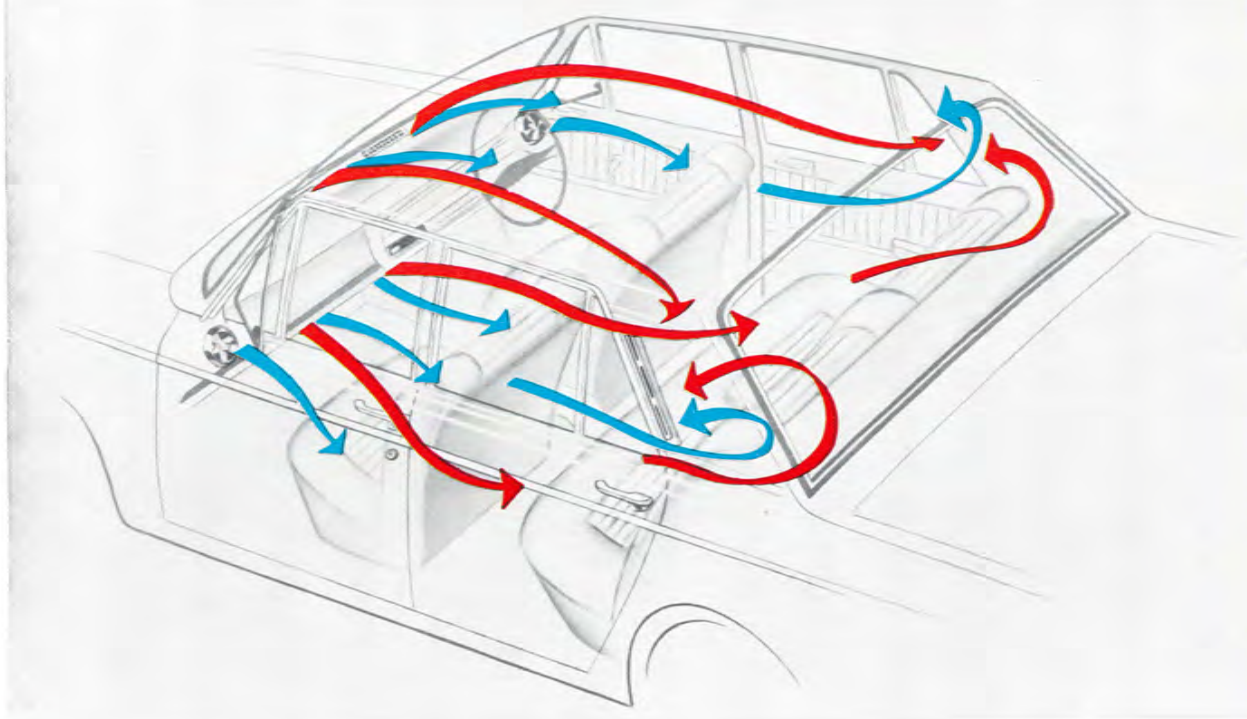

**Ventilation and heater controls:** Styled into instrument panel, centre location for easy reach of both driver and front passenger. Standard equipment on Hunter. (Heater optional extra on Arrow).

**How the ventilation system works:** Fresh air is drawn through top grille intake and enters the car through two special vents in the instrument panel. These can be regulated to direct the flow and volume of air required. Air also gains entry through the vents above and below the instrument panel in the Hunter (this also applies to the Arrow when heater is fitted). Air flows gently and continuously through the interior, being expelled through the special extractors behind the rear doors. Blue arrows in diagram show flow of cool air. Red arrows show flow of heated air as applicable to the Hunter. (This also applies to the Arrow when heater is fitted).

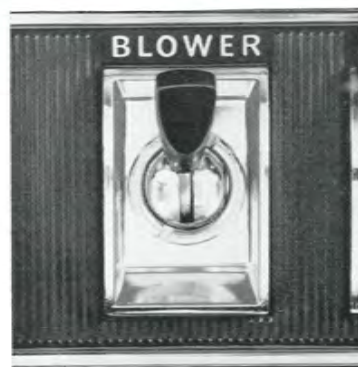

**Blower Switch:** To increase intake of fresh air through the vents, or to boost flow of heated air in car or to windscreen. Standard on Hunter. (With heater, on Arrow as an optional extra).



**Swivelling Fresh Air Vents:** Located each side of the instrument panel. Individually controlled for directing air wherever you choose. Simply twist centre knob to regulate volume of air required.



**Extractor Vents:** Stylishly designed extractor vents are located on both sides of the car behind the rear door windows. The extractor vents are neatly recessed into the body panel.



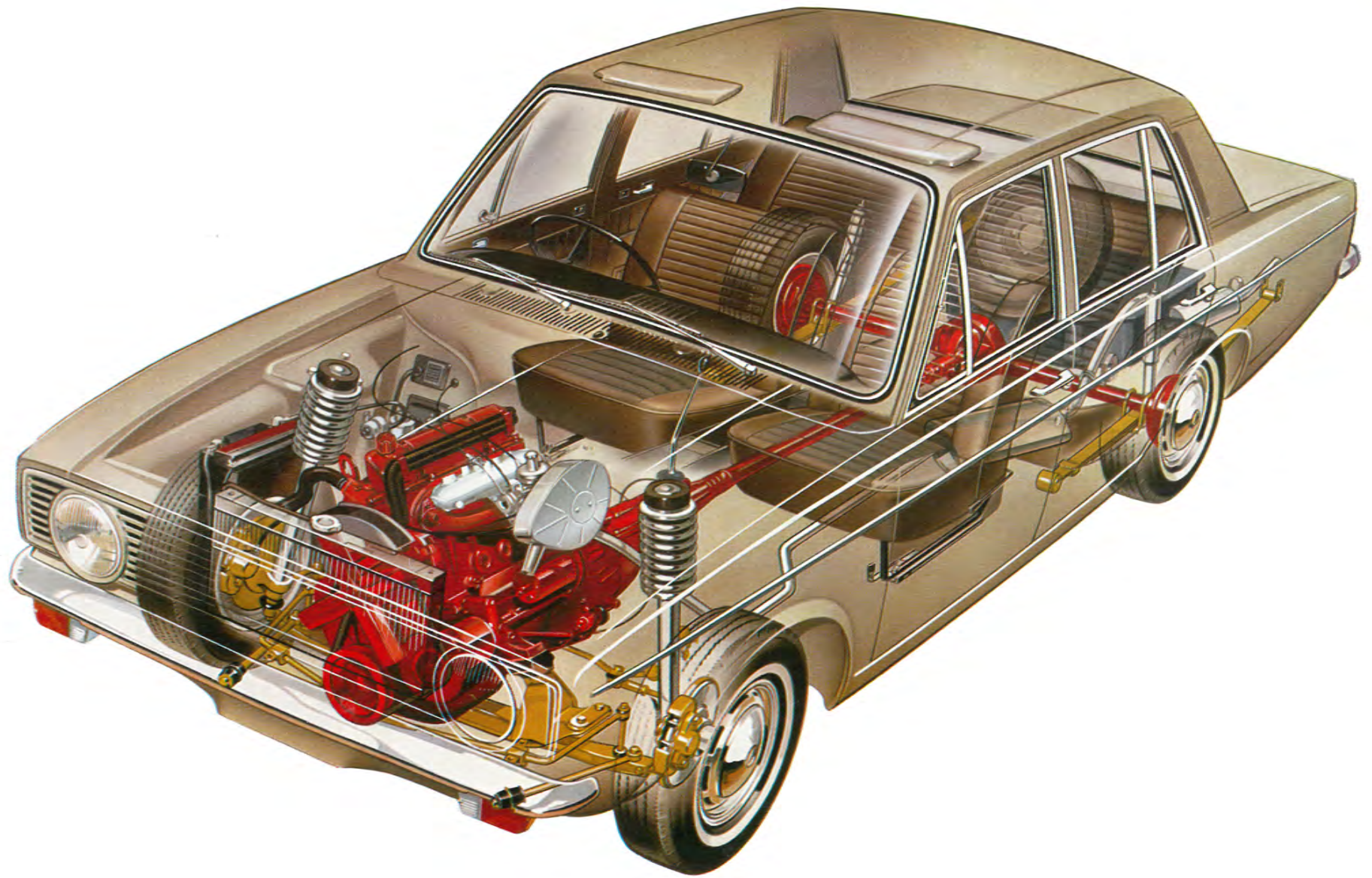

**Balanced safety design  
with so many first-rate features**

In designing the Hillman Arrow and Hunter, safety was a major consideration. Apart from the many safety features you can see, or use, safety is built into every stage of manufacture. Tough all-steel unitary construction, with body and frame welded into one immensely strong unit. Wide wheel tracks that increase the car's stability. Seating that is cradled well within the wheelbase. Balanced weight distribution and a low centre of gravity to ensure first class tenacious road-holding. The Hillman Arrow and Hunter are built and equipped for safety and to give years of reliable service.

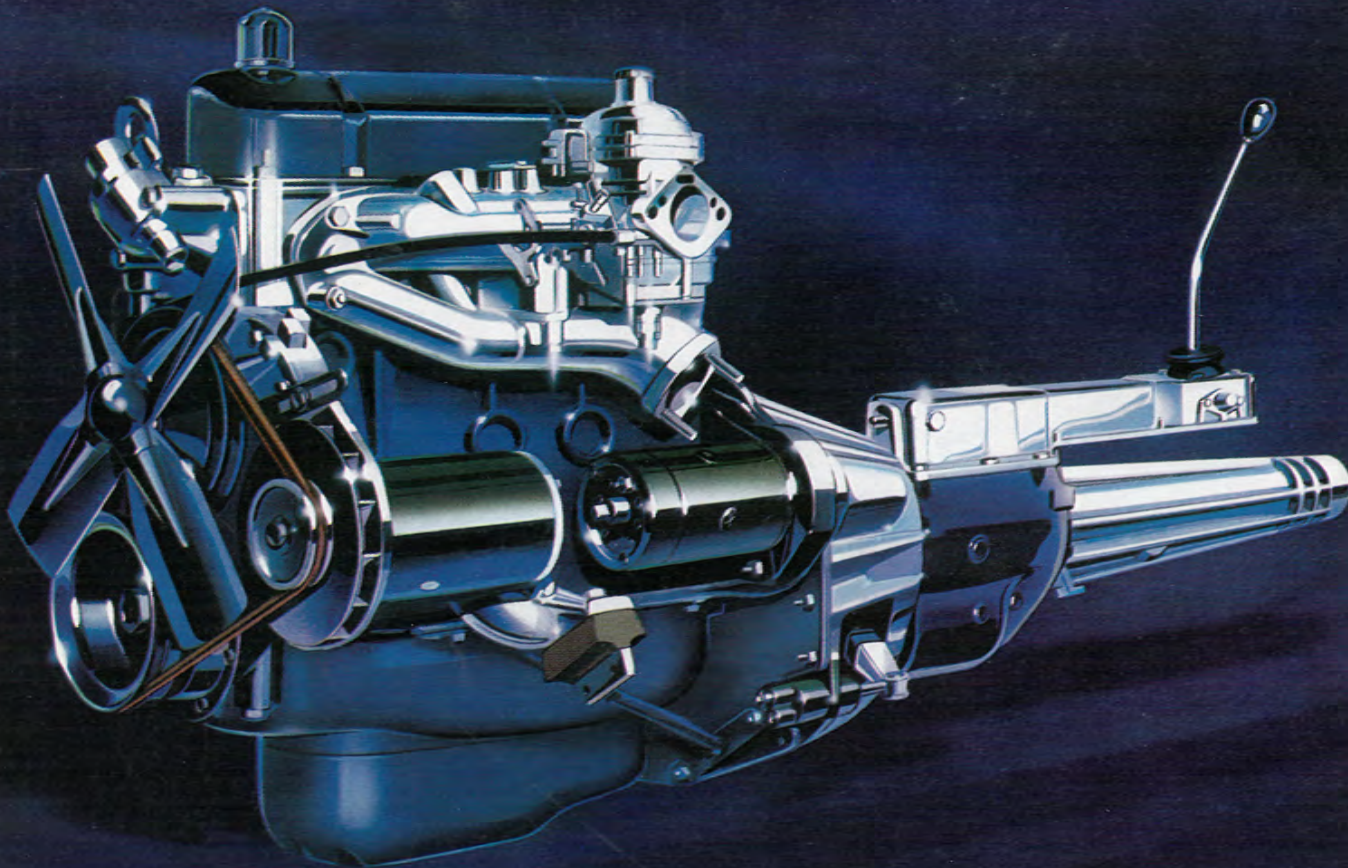

## Smooth, powerful performance with real economy

Smooth, quiet yet powerful performance is provided by the 1725 c.c. O.H.V. engine. Features include, modern "square" design, constant depression carburettor for improved breathing and outstanding economy, 5-bearing crankshaft for smooth running, efficient air cleaner, large oil pump capacity, and exceptional power-to-weight ratio. The Arrow and Hunter's "slant 4" engine is the ideal power unit for an every-purpose family car.

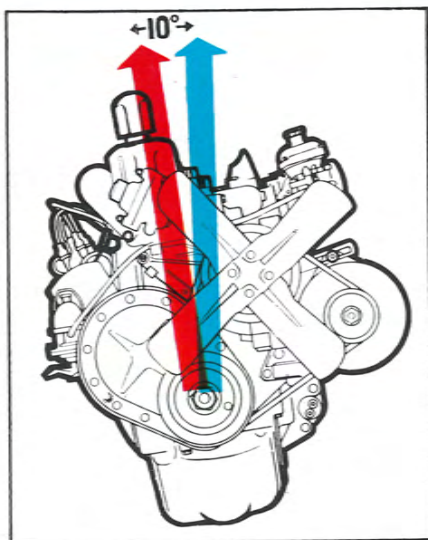

### "Slant 4" design:

Engine is angled at 10 degrees. This economises space, gives a smart low bonnet line, minimises wind resistance and improves forward vision. Engine develops 73 b.h.p. at 4,900 r.p.m. Maximum torque 99.5 lbs. ft. at 2,700 r.p.m.

### Tenacious Road-holding:

Refined suspension system features new front strut assemblies embodying high rated coil springs and in-built shock absorbers. Struts are mounted on upper and lower swivel bearings to ensure light, easy steering action. At the rear, long, wide leaf springs combine with angled, double acting shock absorbers to give complete ride comfort. Anti-roll bar at the front gives extra stability and greatly improves road-holding qualities.

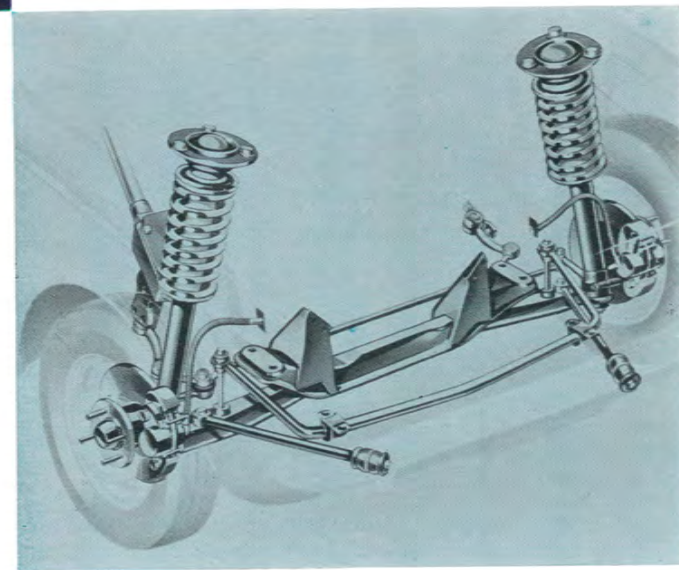

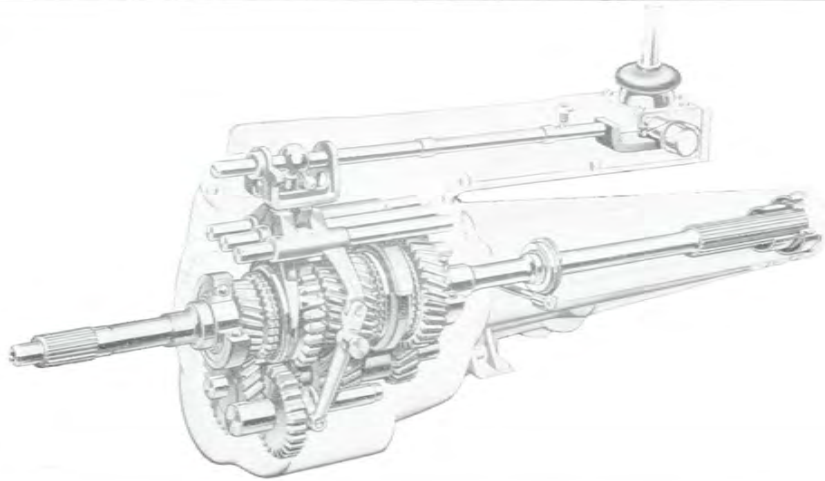

**4-Speed Synchromesh Gearbox:** Gives smooth quick changes in all gears, up or down. Centre floor gear change mounted in centre console. The large diaphragm spring clutch is hydraulically operated and needs only light application of pressure.

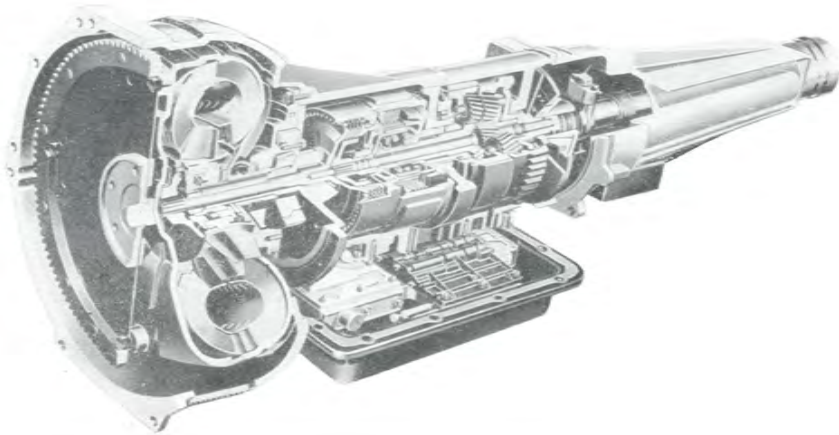

**Fully Automatic Transmission:** Both Arrow and Hunter offer the choice of fully automatic transmission. Gear changing is smooth, silent and entirely automatic. Gear selector lever is mounted in the centre floor console.

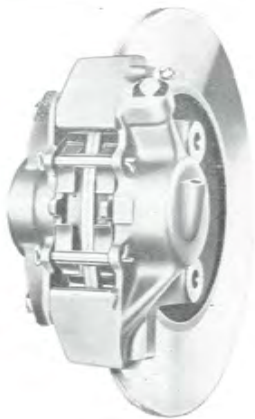

**Front Disc Brakes:** Combination of front disc brakes and large diameter rear drum brakes give powerful, safe braking. All brakes are self-adjusting.

# HILLMAN *Arrow & Hunter*

## Feature Summary:

- "Slant 4" 1725 c.c. engine
- 5-bearing crankshaft
- Highly efficient suspension system
- No greasing points
- Long-interval servicing
- 4-point jacking system
- All synchromesh 4-speed gearbox

- Front disc brakes
- Self-adjusting brakes
- Padded instrument panel
- Padded twin sun visors
- Double-sided safety rim wheels
- Child-proof locks to rear doors
- Anti-burst locks
- Windscreen washers
- Built-in seat belt anchor points
- Safety zone windscreen
- Dished steering wheel
- Reversing lights
- Small turning circle (33.5 ft.)

- Individual "form-contoured" front seats
- 5-seater space and comfort
- Ample interior stowage space
- Enclosed glove box
- Coat hook
- Ash tray in all 4 doors
- Clear-view instrument panel
- Controlled fresh air ventilation
- Opening vent windows on front doors
- 18 cubic feet luggage compartment



## Specifications:

**ENGINE.** Four cylinder five-bearing crankshaft unit with push rod operated overhead valves. Zenith/Stromberg side-draught carburettor. Bore and stroke: 3.21 in. 3.25 in. Cubic capacity 105.2 cu. in. (1,725 c.c.). Compression ratio 8.4:1. Maximum power 73 b.h.p. at 4,900 r.p.m. with maximum torque 99.5 lbs. ft. at 2,700 r.p.m.

**IGNITION.** 12 volt negative earth battery on right of engine: coil and distributor with fully automatic centrifugal and vacuum control.

**COOLING.** Centrifugal pump and fan, thermostatic control.

**CLUTCH.** 7½ in. diameter diaphragm spring type, hydraulically operated from pendant pedal.

**TRANSMISSION—MANUAL.** Four speed all-synchromesh on forward gears, central console mounted gear lever. Ratios 1st 3.353:1, 2nd 2.141:1, 3rd 1.392:1, 4th 1.0:1, Reverse 3.569:1.

**TRANSMISSION—AUTOMATIC.** Borg-Warner 35. Three speed with torque convertor, central console mounted gear selector. Selector Pattern:—  
L - Low Lock, D - Drive, N - Neutral, R - Reverse, P - Park. Ratios — Low 2.39:1, Interm. 1.45:1, Drive 1.00:1, Reverse 2.09:1.

**REAR AXLE.** Semi-floating hypoid bevel type, ratio: 3.89:1.

**UNITARY CONSTRUCTION** of chassis and body rigid lowstress design.

**FRONT SUSPENSION.** Fully independent coil springs and strut type, with anti-roll bar and telescopic shock absorbers integral with strut. No greasing points.

**REAR SUSPENSION.** Semi-elliptic leaf springs with telescopic shock absorbers. No greasing points.

**STEERING.** Recirculating ball type, Turns from lock to lock 3.3. Turning circle 33½ ft. Two spoke dished steering wheel. No greasing points.

**BRAKES.** 9.6 in. diameter disc brakes at front, and 9 in. diameter self-adjusting drum brakes at rear, with hydraulic operation. Handbrake at driver's side operates mechanically and independently on rear wheels.

**WHEELS.** Pressed steel wheels with safety rims. Spare wheel carried in luggage compartment.

**TYRES.** Tubeless type, size 6.00 x 13 in.

**PETROL TANK.** 10 Imperial gallon capacity, positioned at rear.

**WEIGHTS** (approx.) Unladen (with petrol and water): 2,083 lbs. Add 37 lbs. for auto transmission.

**INSTRUMENTS.** Speedometer, fuel gauge and water temperature gauge, and warning lights for ignition, oil pressure, headlamp main beam and direction indicators.

**STANDARD EQUIPMENT.** Two padded sun visors, heater with two-speed blower (Hunter), Flo-Thru ventilation system, windshield washers, reclining passenger seat (Hunter), Door armrests (Hunter), Door pulls (Arrow), cigar lighter (Hunter), coat hook, modified zone windshield, rear door child-proof locks, front door courtesy switches, front and rear ash receivers, whitewall tyres (Hunter), wheel trim rings (Hunter) reversing lights, carpet floor covering (Hunter), front parcel shelf, trunk compartment lamp (Hunter).

*Heater with blower is available as an optional extra on Arrow, but must be specified at the time of placing the order. A full range of accessories also available.*

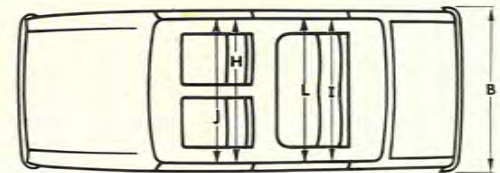
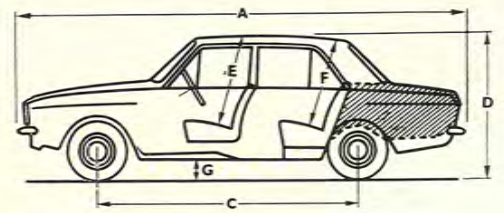

### Dimensions:

	ins.
A. Overall length.....	168.0
B. Overall width.....	63.5
C. Wheelbase.....	98.5
D. Overall height.....	56.0
E. Front headroom.....	37.3
F. Rear headroom.....	36.2
G. Ground clearance.....	6.8
H. Front shoulder room.....	52.2
I. Rear shoulder room.....	52.0
J. Front hip room.....	53.4
L. Rear hip room.....	53.5

*The policy of Chrysler Limited is one of continual improvement in design and manufacture wherever possible to assure a still finer car. Hence specifications, equipment and prices are subject to change without notice.*

Specialised Service and Genuine Chrysler Parts available Nationwide. Vehicles are covered by the Chrysler 12/12 warranty.



**CHRYSLER  
AUSTRALIA LTD.**

**CLEM SMITH MOTORS**

152 WEST TERRACE

ADELAIDE

MAIN HILLMAN DEALERS

PHONE 51 3189